

TEMPERATURE CHAMBERS

(- 40 °C ...+ 180 °C)

Model:

TK-68 CKLT

TK-190 CKLT

TK-340 CKLT

TK-500 CKLT

TK-1000 CKLT

- Material temperature resistance and product testing
 - Maintaining superior temperature & Rh stability
 - Sample conditioning prior to other tests
 - Data loggers and sensors calibration
 - Temperature controlled test polygon
 - World class metrology performance
 - Accelerated ageing
 - Stress tests

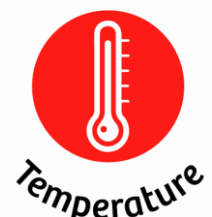

Device description:



Fan for internal air circulation with speed control

7" capacitive touch screen controller with user friendly interface, advance settings options, Ethernet and USB communication ports

2 level over temp. protection:
1. 5°C over set point heating disabled
2. 10°C above max. temp mechanical shut off

Extensive heat insulation shield on all chamber sides

Main switch

Access port with both end plugs Ø50 mm (On left side)

All exterior in galvanized and powder coated aluminized steel

Door sealed with double soft profile silicone seal to ensure perfect tightness

Heavy duty closing mechanism with key lock

Height Adjustable stainless steel wire shelves (1 pcs included)

Full door heated observation window with LED illumination

Heavy duty swivel wheels with brake for simple manipulation

Full 4 side maintenance access to ref. system

Fully stainless-steel interior chamber

Touch display with advanced controller functions:

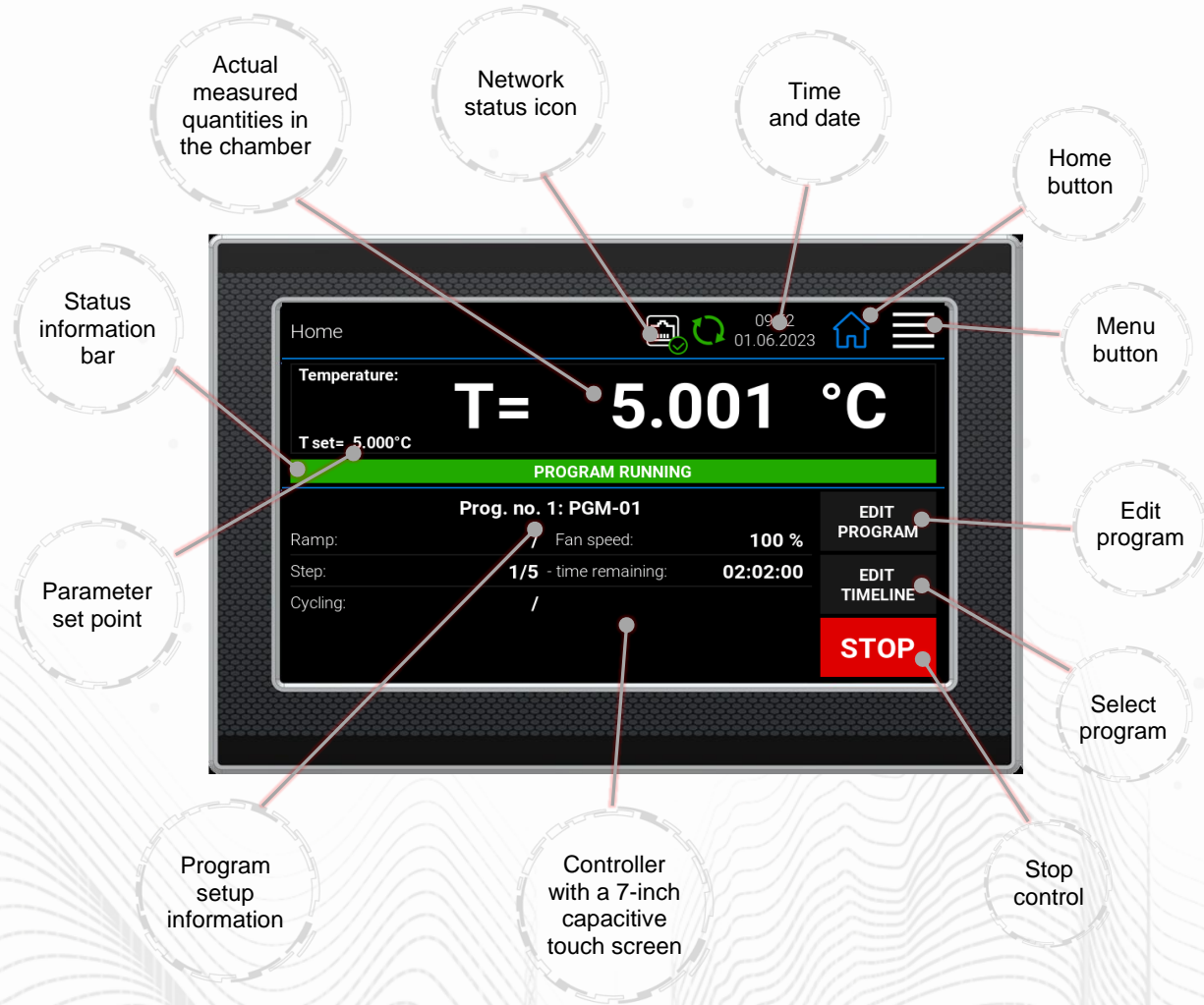

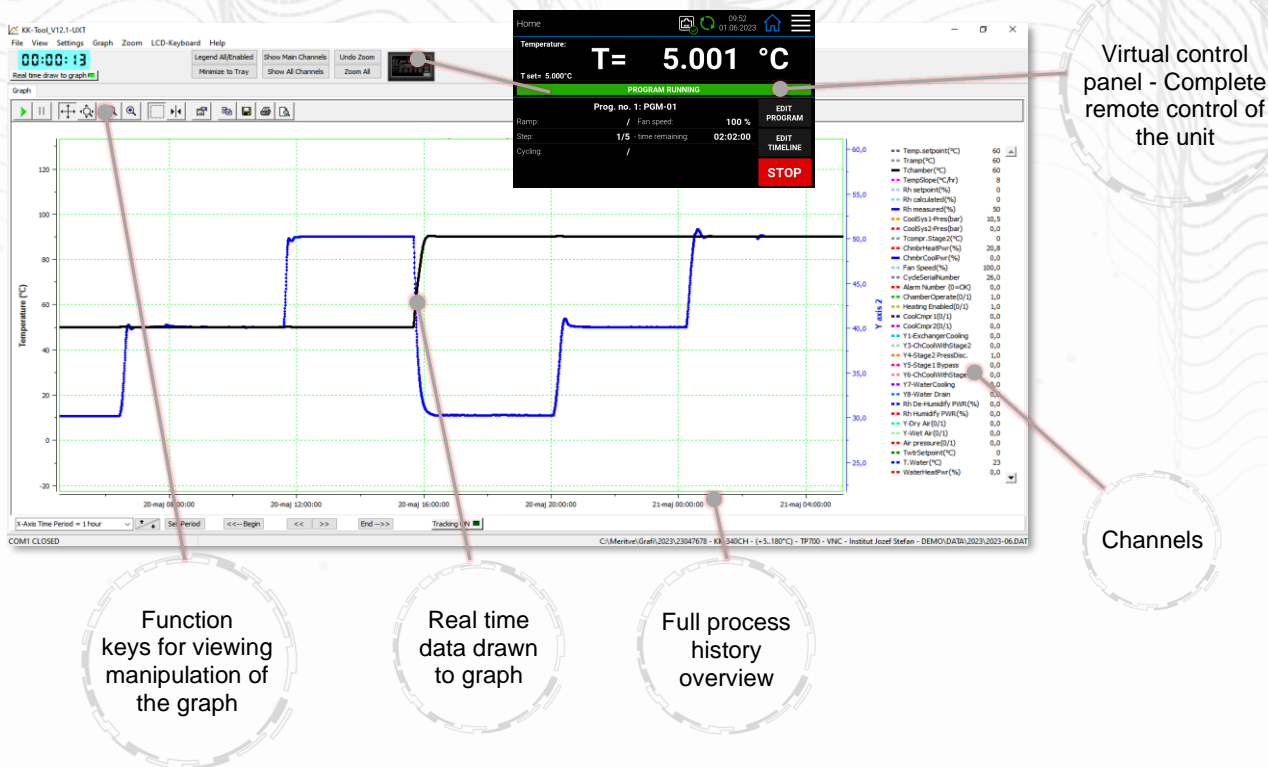

KK-Tool software for PC (free – included with every unit):



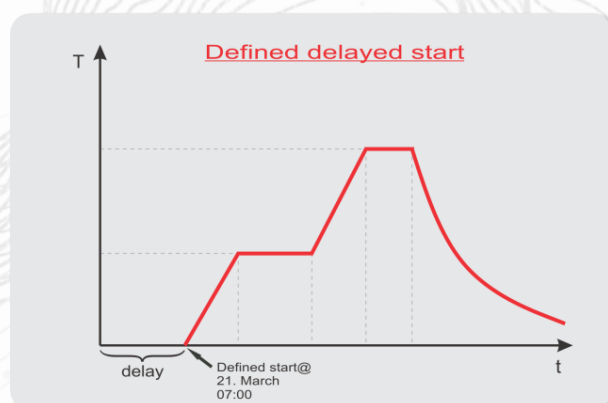
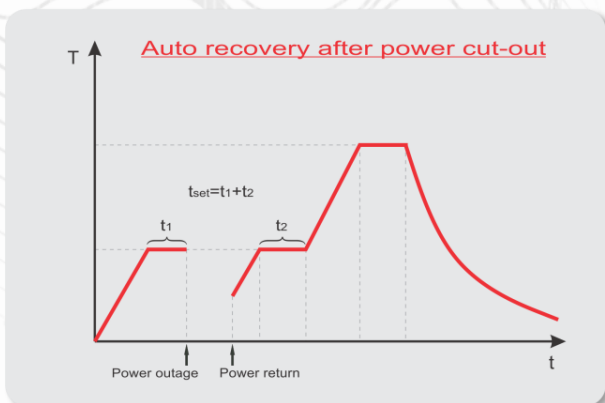
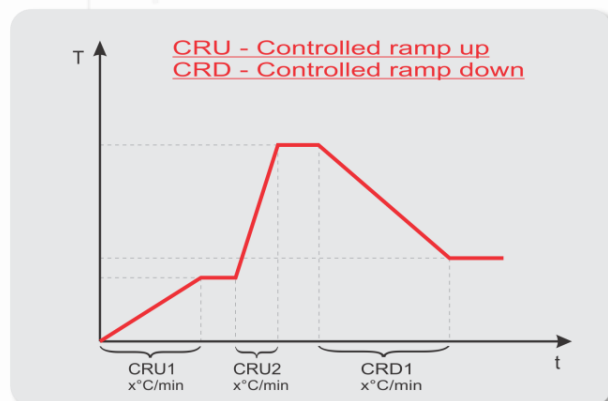
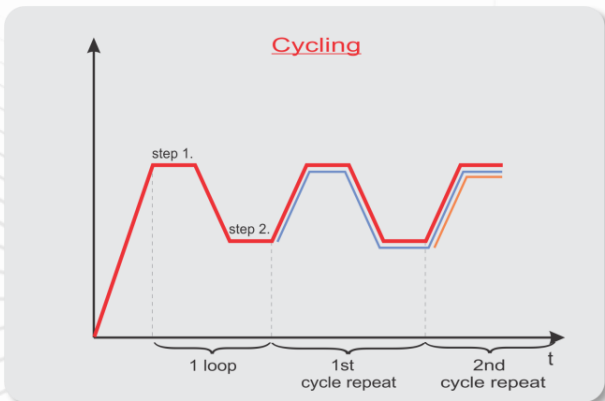
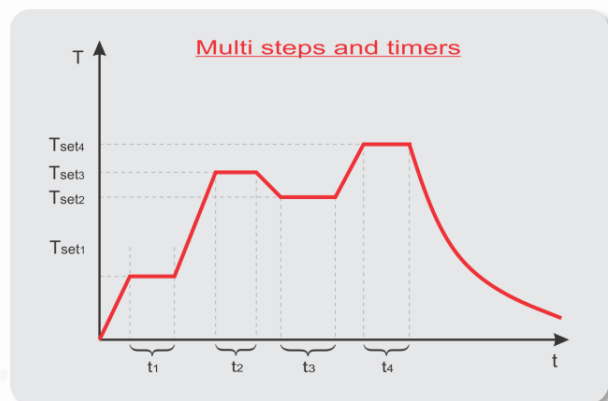
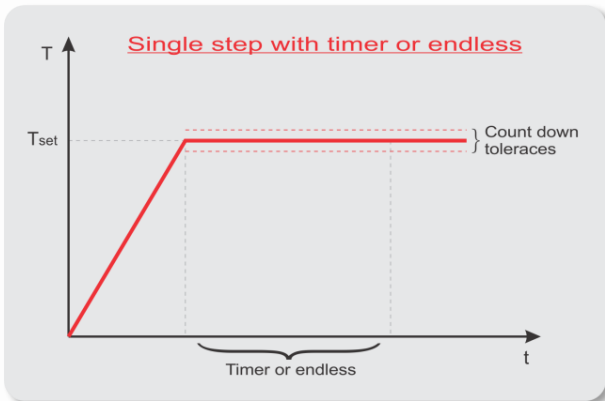

Controller functions:



	TK-68 CKLT	TK-190 CKLT	TK-340 CKLT
			
External dimensions (WxHxD) [mm]	650 x 1223 x 796	835 x 1661 x 951	835 x 1881 x 1126
Internal dimensions (WxHxD) [mm]	410 x 475 x 350	600 x 615 x 510	600 x 835 x 685
Volume [L]	~ 68	~ 190	~ 340
Temperature range [°C]	- 40 ...+ 180	- 40 ...+ 180	- 40 ...+ 180
Heat up rate [°C/min] (according to EN 60068-3-5)	4.0	2.0	1.5
Cool down rate [°C/min] (according to EN 60068-3-5)	2.5	2.5	2.5
Temperature display res [°C]	0.1	0.1	0.1
Temperature set res. [°C]	0.1	0.1	0.1
Temperature stability [°C]	± 0.2°C @ - 40°C ± 0.05°C @ 50°C ± 0.05°C @ 90°C ± 0.2°C @ 180°C	± 0.2°C @ - 40°C ± 0.05°C @ 50°C ± 0.05°C @ 90°C ± 0.2°C @ 180°C	± 0.2°C @ - 40°C ± 0.1°C @ 50°C ± 0.1°C @ 90°C ± 0.2°C @ 180°C
Temperature uniformity [°C]	± 1.0°C @ - 40°C ± 0.3°C @ 50°C ± 0.3°C @ 90°C ± 2.5°C @ 180°C	± 1.0°C @ - 40°C ± 0.3°C @ 50°C ± 0.3°C @ 90°C ± 1.5°C @ 180°C	± 0.5°C @ -40°C ± 0.2°C @ 50°C ± 0.2°C @ 90°C ± 1.0°C @ 180°C
Heat compensation [W]	~ 100 @ - 30 °C ~ 800 @ - 5 °C ~ 1500 @ + 20 °C	~ 350 @ - 30 °C ~ 1500 @ - 5 °C ~ 3000 @ + 20 °C	~ 350 @ - 30 °C ~ 1500 @ - 5 °C ~ 3000 @ + 20 °C
Temperature control	PID (PT-100)	PID (PT-100)	PID (PT-100)
Power supply	230V 50/60 Hz	230V 50/60 Hz	230V 50/60 Hz
Wattage [W]	3500	3600	3600
Interface	USB and Ethernet	USB and Ethernet	USB and Ethernet
Shelve	1 (max 6)	1 (max 8)	1 (max 8)
Shelve capacity [kg]	25	35	35
Max capacity [kg]	40	80	100
Observation window	As standard	As standard	As standard
Access port [mm]	Ø 50 (left side)	Ø 50 (left side)	Ø 50 (left side)
Noise [dBA] @ 1 m distance	58	60	60
Weight [kg]	190	273	319

*All performance in controlled environment ($T_{ambient} = 22\text{ °C} \pm 3\text{ °C}$)!

*Accessories might affect performance!

	TK-500 CKLT	TK-1000 CKLT
		
External dimensions (WxHxD) [mm]	1035 x 1880 x 1381	1235 x 1928 x 1579
Internal dimensions (WxHxD) [mm]	800 x 835 x 800	1000 x 1035 x 1000
Volume [L]	~ 500	~ 1000
Temperature range [°C]	- 40 ...+ 180	- 40 ...+ 180
Heat up rate [°C/min] (according to EN 60068-3-5)	3.0	3.0
Cool down rate [°C/min] (according to EN 60068-3-5)	2.5	2.5
Temperature display res [°C]	0.1	0.1
Temperature set res. [°C]	0.1	0.1
Temperature stability [°C]	± 0.2°C @ - 40°C ± 0.1°C @ 50°C ± 0.1°C @ 90°C ± 0.2°C @ 180°C	± 0.2°C @ - 40°C ± 0.1°C @ 50°C ± 0.1°C @ 90°C ± 0.2°C @ 180°C
Temperature uniformity [°C]	± 1.0°C @ - 40°C ± 0.5°C @ 50°C ± 1.0°C @ 90°C ± 1.5°C @ 180°C	± 1.0°C @ - 40°C ± 0.5°C @ 50°C ± 1.0°C @ 90°C ± 1.5°C @ 180°C
Heat compensation [W]	~ 500 @ - 30 °C ~ 1500 @ - 5 °C ~3000 @ +20 °C	~ 500 @ - 30 °C ~ 3000 @ - 5 °C ~5000 @ +20 °C
Temperature control	PID (PT-100)	PID (PT-100)
Power supply	3x400V 50/60Hz	3x400V 50/60Hz
Wattage [W]	9000	12000
Interface	USB and Ethernet	USB and Ethernet
Shelve	1 (max 8)	1 (max 8)
Shelve capacity [kg]	50	50
Max capacity [kg]	150	200
Observation window	As standard	As standard
Access port [mm]	Ø 50 (left side)	Ø 50 (left side)
Noise [dBA] @ 1 m distance	62	62
Weight [kg]	430	599

*All performance in controlled environment ($T_{ambient} = 22 \text{ °C} \pm 3 \text{ °C}$)!

*Accessories might affect performance!

Ordering information and accessories:

Description	Part no.
Climatic chamber TK-68 CKLT	791
Climatic chamber TK-190 CKLT	2513
Climatic chamber TK-340 CKLT	2516
Climatic chamber TK-500 CKLT	1746
Climatic chamber TK-1000 CKLT	2519
Shelve wire TK-68 CKLT	792
Shelve wire TK-190 CKLT	953
Shelve wire TK-340 CKLT	956
Shelve wire TK-500 CKLT	958
Shelve wire TK-1000 CKLT	960
Shelve perforated TK-68 CKLT	793
Shelve perforated TK-190 CKLT	954
Shelve perforated TK-340 CKLT	957
Shelve perforated TK-500 CKLT	959
Shelve perforated TK-1000 CKLT	961
Access Port w. Plug Ø 50 mm right (specify position)	899
Access Port w. Plug Ø 90 mm right (specify position)	900
Trolley for TK-68 CKLT	794
Evaluation report 9 points, 3 temperatures - performed by Kambic	1719
Evaluation report 9 points, 3 temperatures- Accredited	2852

**Accessories might affect performance!*

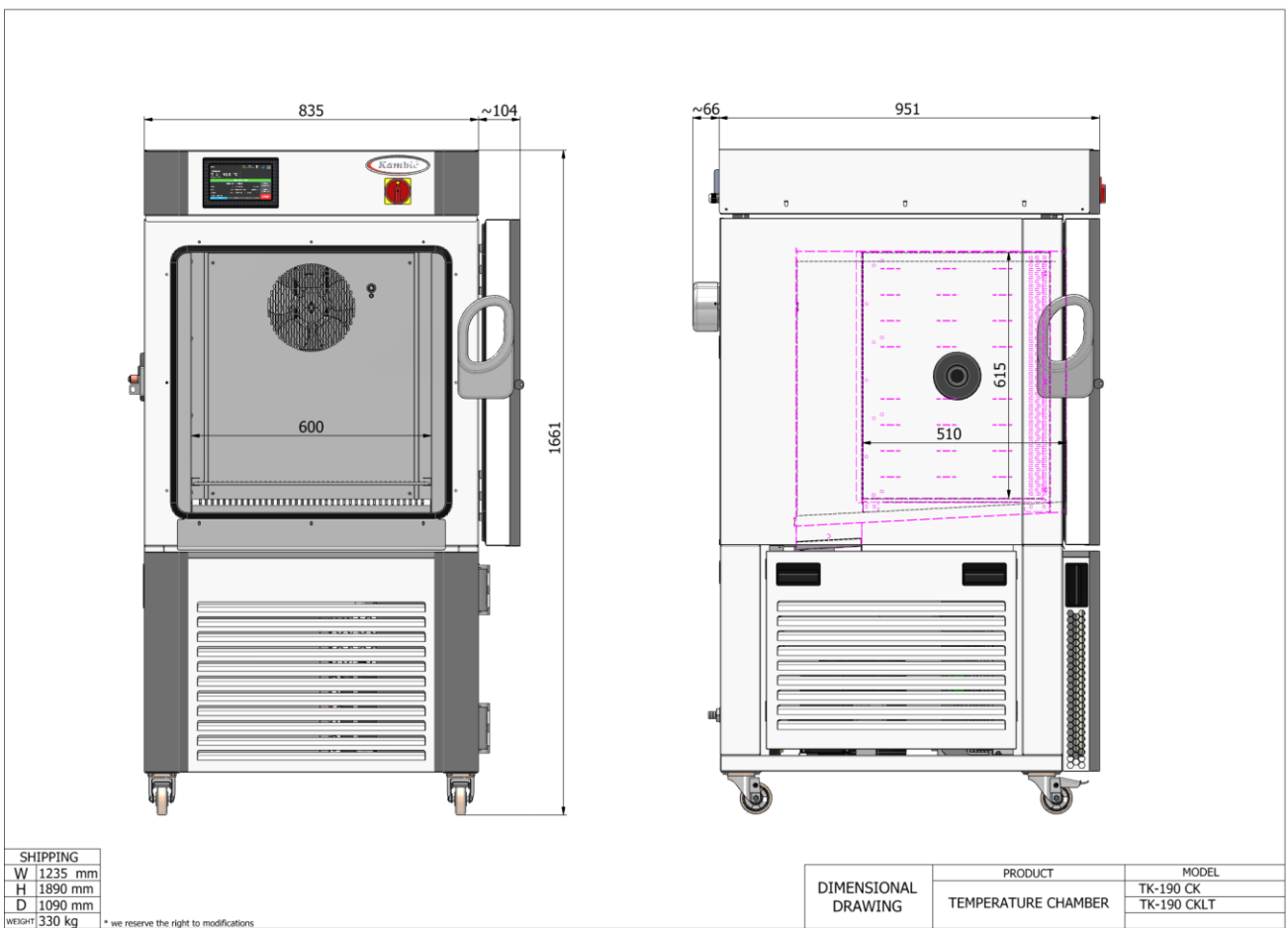
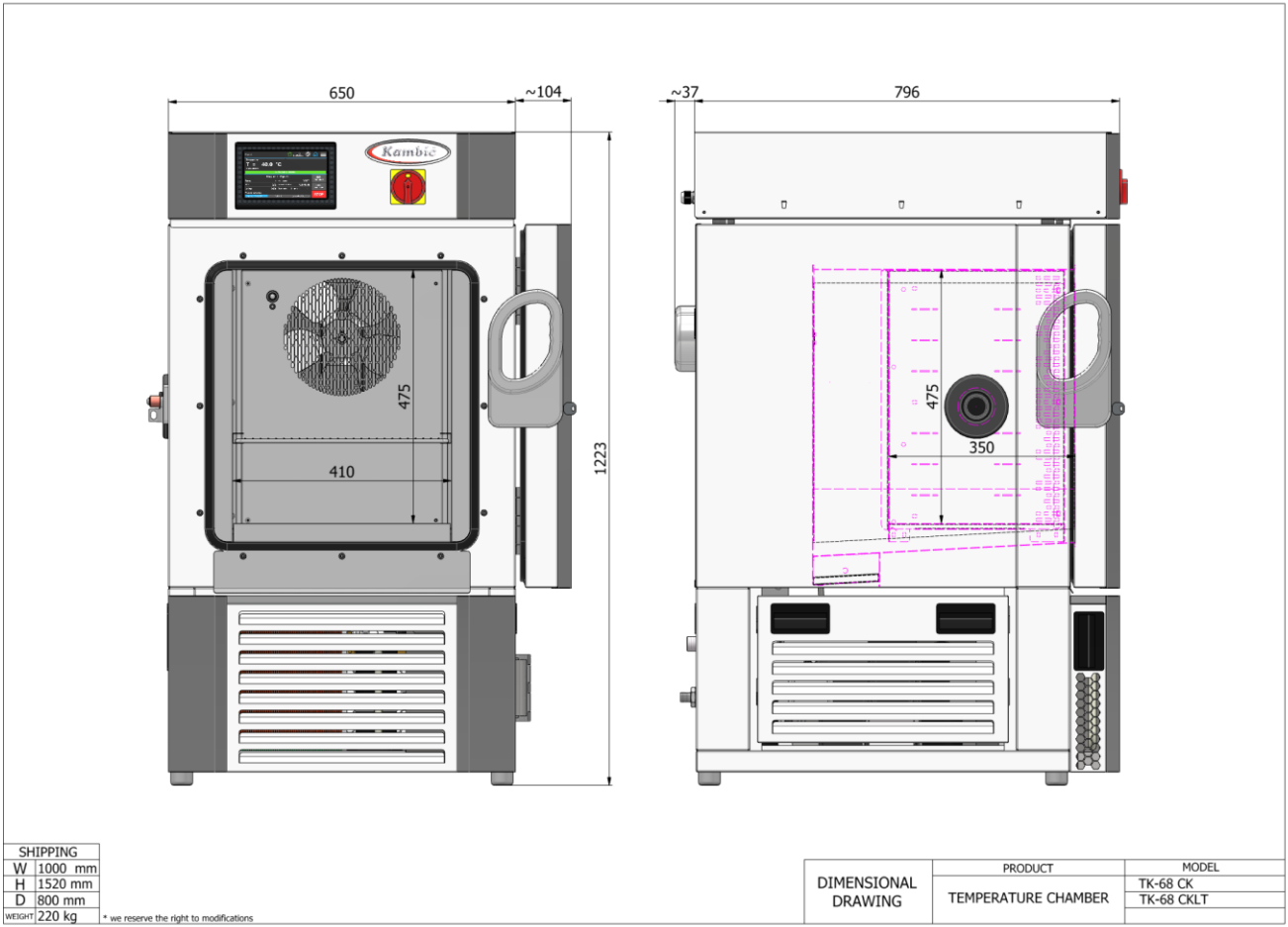

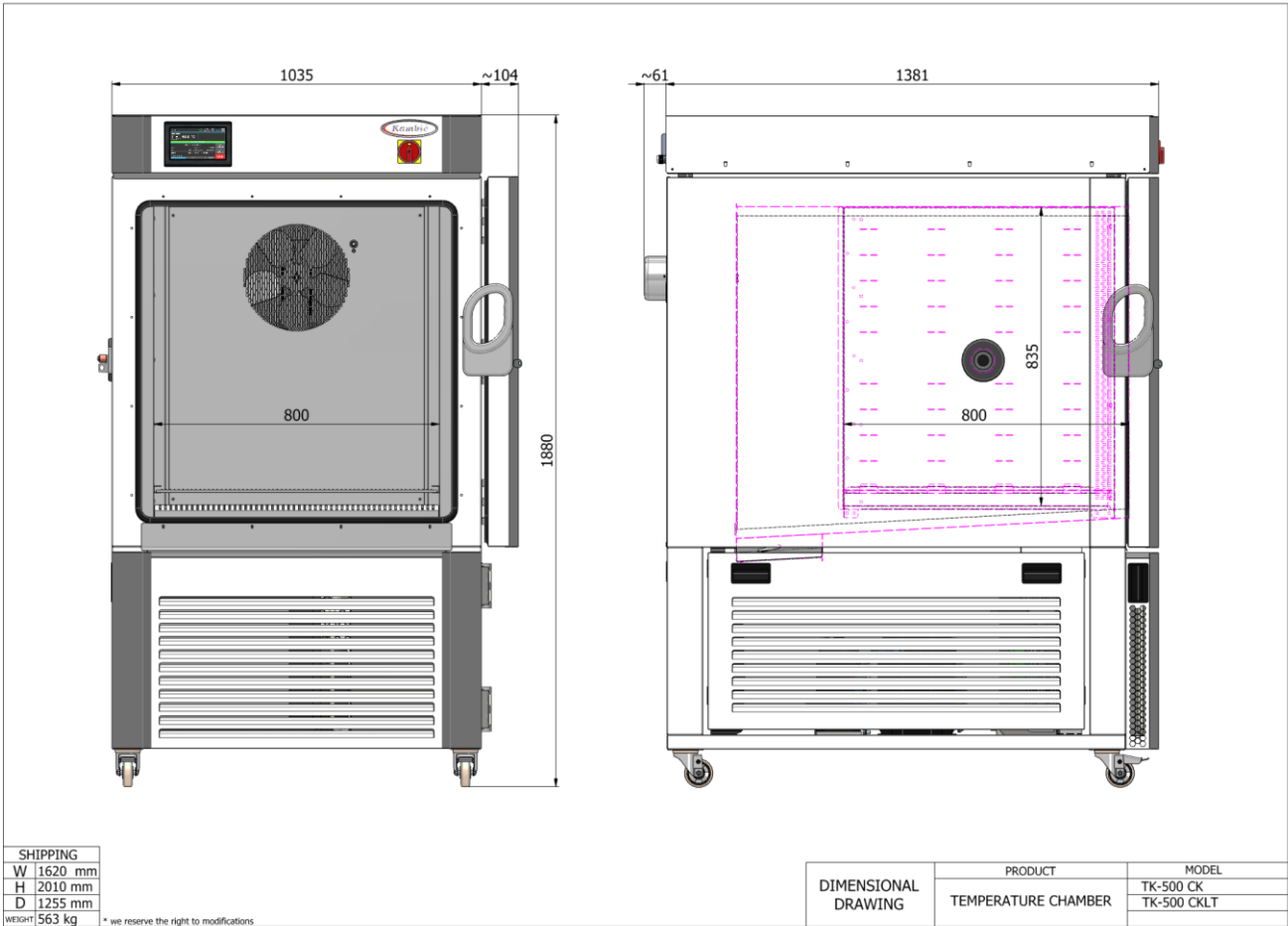
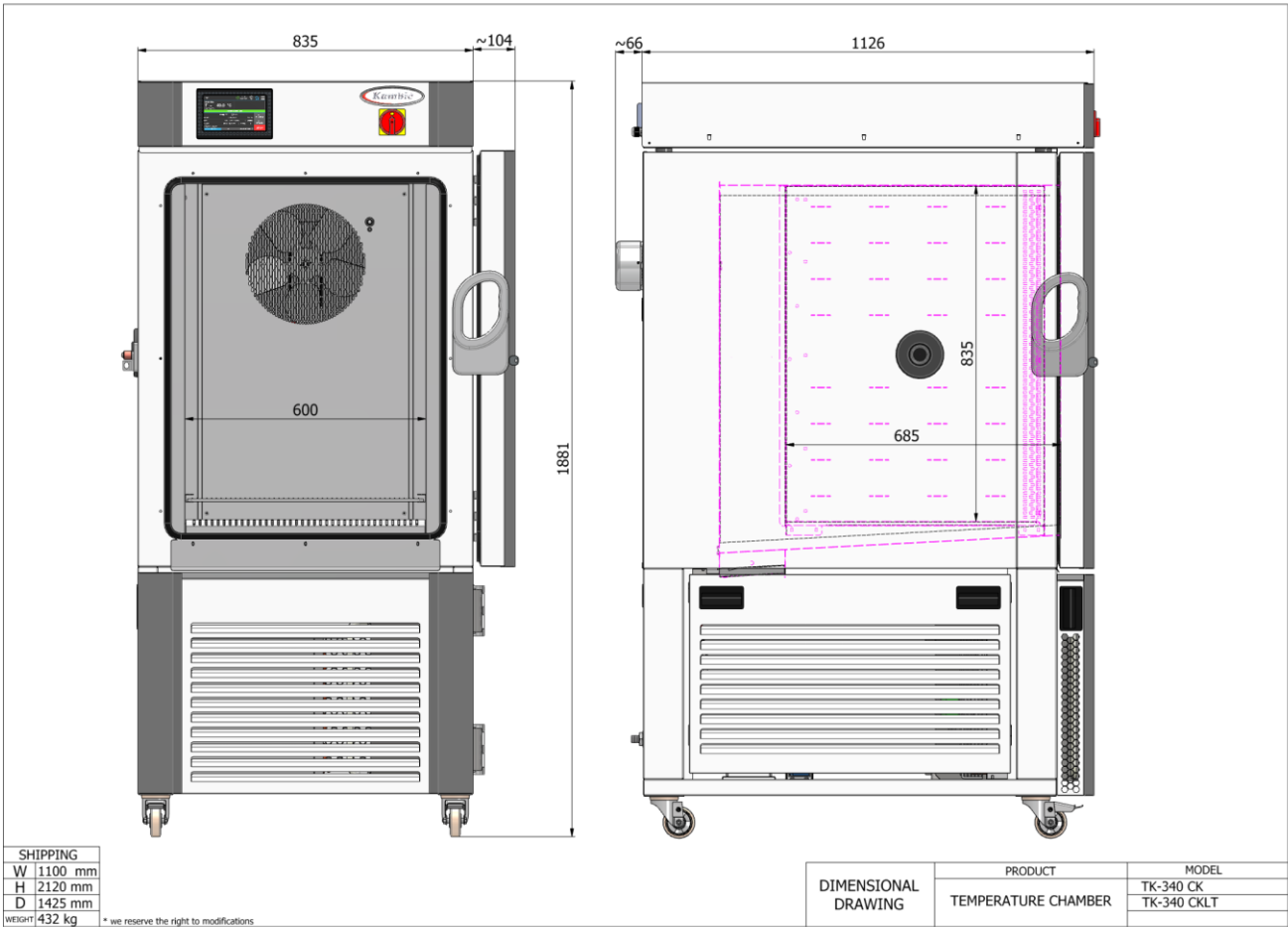

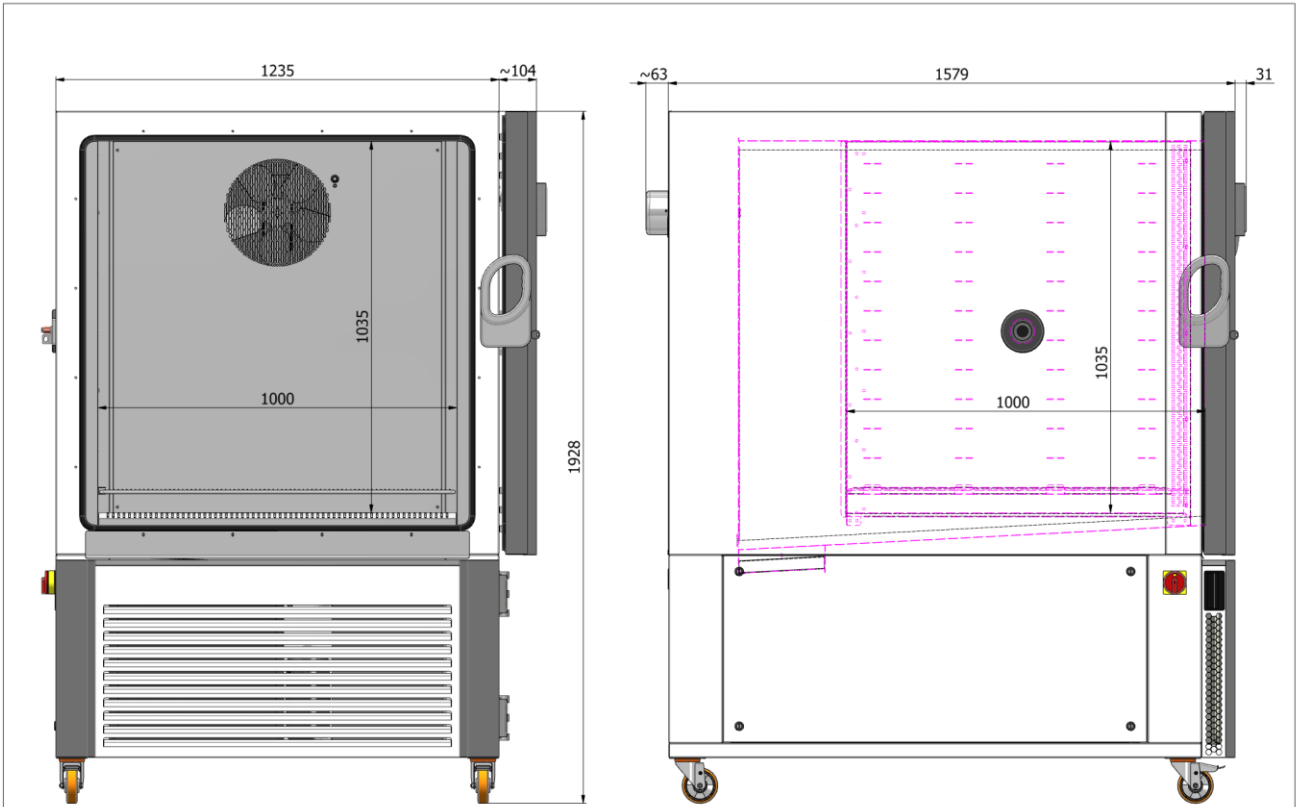

SHIPPING	
W	1450
H	2120
D	1830
WEIGHT	600

* we reserve the right to modifications

DIMENSIONAL DRAWING	PRODUCT	MODEL
	TEMPERATURE CHAMBER	TK-1000 CK TK-1000 CKLT

