



# HMP7 Relative Humidity and Temperature Probe

For high humidities



## Features

- RH accuracy up to  $\pm 0.8$  %RH
- Temperature accuracy up to  $\pm 0.1$  °C ( $\pm 0.18$  °F)
- Temperature measurement range  $-70 \dots +180$  °C ( $-94 \dots +356$  °F)
- Vapor and pressure proof construction
- Condensation prevention with probe heating
- Sensor purge provides superior chemical resistance
- Modbus® RTU over RS-485
- Compatible with Indigo transmitters and Insight PC software
- Traceable calibration certificate: 6 points for humidity, 1 point for temperature

Vaisala HUMICAP® Humidity and Temperature Probe HMP7 is designed for applications that involve constant high humidity or rapid changes in humidity, such as drying and test chambers, combustion air, and other humidifiers and meteorological measurements, where measurement performance and chemical tolerance are essential.

### Proven Vaisala HUMICAP® performance

Vaisala is the original innovator of the thin-film capacitive humidity measurement technology, which has now become the industry standard in humidity measurement.

HUMICAP® technology results from Vaisala's 40-year experience in industrial humidity measurement, providing the best stability, fast response time, and low hysteresis in a wide range of applications.

### Avoiding condensation at extreme humidity

Probe heating functionality heats up not only the sensor, but the whole probe head. When probe temperature is heated above dew point temperature, condensation on the probe can be avoided while measuring the dew point

temperature of the process. By setting the temperature compensation value obtained, for example, with the TMP1 temperature probe, true relative humidity at process temperature can be measured while avoiding condensation by elevated probe temperature.

### Vaisala Indigo product family

Indigo transmitters extend the capabilities of Indigo compatible measurement probes. The transmitters can display measurements on the spot as well as transmit them to automation systems through analog signals, digital outputs, and relays. Cable length between probe and transmitter can be extended to up to 30 meters. For more information, see [www.vaisala.com/indigo](http://www.vaisala.com/indigo).

### Flexible connectivity

The probe is compatible with Vaisala Indigo series transmitters, and it can be used as a standalone digital Modbus RTU transmitter over RS-485 serial bus. For easy-to-use access to field calibration, device analytics, and configuration functionality, the probe can be connected to Vaisala Insight software for Windows®. For more information, see [www.vaisala.com/insight](http://www.vaisala.com/insight).



DNV GL type approval certificate no. TAA00002YT

# Technical data

## Measurement performance

### Relative humidity

Measurement range	0 ... 100 %RH
Accuracy at +23 °C (+73.4 °F) <sup>1)</sup>	±0.8 %RH (0 ... 90 %RH)
Factory calibration uncertainty <sup>2)</sup>	±0.5 %RH (0 ... 40 %RH) ±0.8 %RH (40 ... 95 %RH)
T <sub>63</sub> response time	15 s
Sensor options	HUMICAP® R2 HUMICAP® R2C <sup>3)</sup> HUMICAP® 180VC <sup>3) 4)</sup>

### Temperature

Measurement range	-70 ... +180 °C (-94 ... +356 °F)
Accuracy at +23 °C (+73.4 °F) <sup>1)</sup>	±0.1 °C (±0.18 °F)
Factory calibration uncertainty <sup>2)</sup>	±0.1 °C (±0.18 °F) at +23 °C (+73.4 °F)
Sensor	Pt100 RTD Class F0.1 IEC 60751

- 1) Defined against calibration reference. Including non-linearity, hysteresis, and repeatability.  
 2) Defined as ±2 standard deviation limits. Small variations possible; see calibration certificate.  
 3) Chemical purge feature available with this sensor.  
 4) H<sub>2</sub>O<sub>2</sub> resistant. With HUMICAP® 180VC sensor, accuracy is not specified below -20 °C (-4 °F) operating temperature.

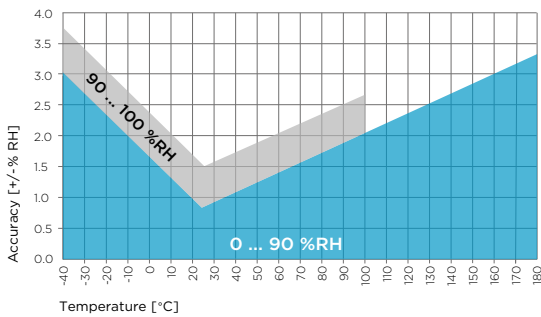

HMP7 humidity measurement accuracy as a function of temperature

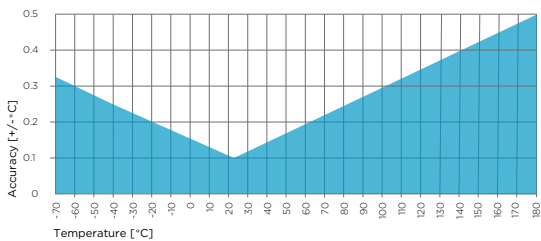

HMP7 temperature measurement accuracy over full range

## Operating environment

Operating temperature of probe body	-40 ... +80 °C (-40 ... +176 °F)
Operating temperature of probe head	-70 ... +180 °C (-94 ... +356 °F)
Operational pressure	< 10 bar
Operating environment	Suitable for outdoor use
Measurement environment	For air, nitrogen, hydrogen, argon, helium, oxygen, and vacuum <sup>1)</sup>
IP rating of probe body	IP66

1) Consult Vaisala if other chemicals are present. Consider safety regulations with flammable gases.

## Inputs and outputs

Operating voltage	18 ... 30 V DC
Current consumption	10 mA typical, 500 mA max.
Digital output	RS-485, non-isolated
Protocols	Modbus RTU

## Output parameters

Absolute humidity (g/m <sup>3</sup> )	Relative humidity (%RH)
Absolute humidity at NTP (g/m <sup>3</sup> )	Relative humidity (dew/frost) (%RH)
Dew point temperature (°C)	Temperature (°C)
Dew/frost point temperature (°C)	Water concentration (ppm <sub>v</sub> )
Dew/frost point temperature at 1 atm (°C)	Water concentration (wet basis) (vol-%)
Dew point temperature at 1 atm (°C)	Water mass fraction (ppm <sub>w</sub> )
Dew point temperature difference (°C)	Water vapor pressure (hPa)
Enthalpy (kJ/kg)	Water vapor saturation pressure (hPa)
Mixing ratio (g/kg)	Wet-bulb temperature (°C)

## Compliance

EU directives	EMC Directive (2014/30/EU) RoHS Directive (2011/65/EU)
EMC compatibility	EN 61326-1, industrial environment
Type approvals	DNV GL certificate no. TAA00002YT
Compliance marks	CE, China RoHS, RCM, WEEE

## Mechanical specifications

Connector	M12 5-pin A-coded male
Weight	310 g (10.9 oz)
<b>Materials</b>	
Probe	AISI 316L
Probe body	AISI 316L
Cable jacket	FEP

## Accessories

Duct installation kit for RH probe	210697
Solar radiation shield DTR502B	DTR502B
Cable gland M20×1.5 with split seal	HMP247CG
Swagelok® for 12 mm probe, 1/2" ISO thread	SWG12ISO12
Swagelok® for 12 mm probe, 3/8" ISO thread	SWG12ISO38
Swagelok® for 12 mm probe, 1/2" NPT thread	SWG12NPT12
Indigo USB adapter <sup>1)</sup>	USB2

1) Vaisala Insight software for Windows available at [www.vaisala.com/insight](http://www.vaisala.com/insight).

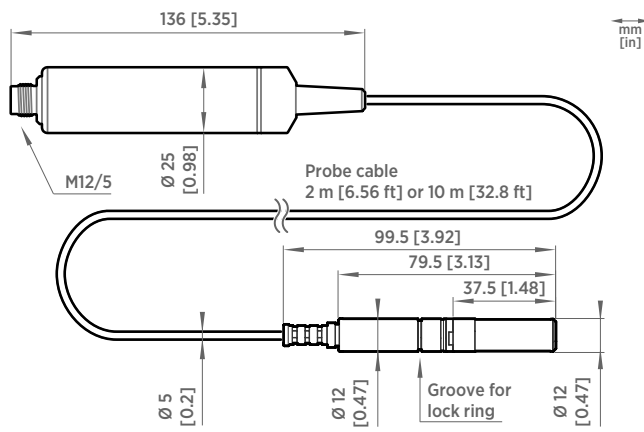

HMP7 probe dimensions

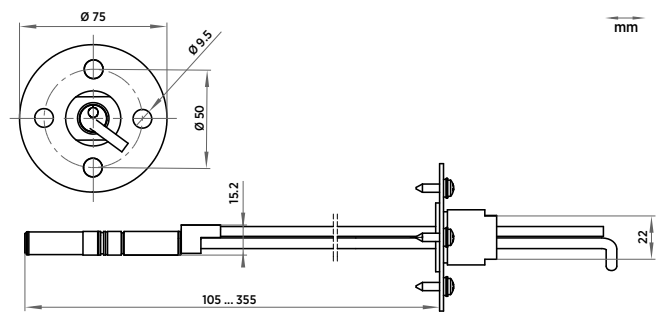

Duct installation kit 210697 dimensions with probe