



Features

- Continuous online measurement of moisture in oil and temperature
- Temperature measurement range $-40 \dots +180 \text{ }^{\circ}\text{C}$ ($-40 \dots +356 \text{ }^{\circ}\text{F}$)
- Measurement accuracy up to $\pm 0.01 a_w$ ($\pm 1 \text{ \%RS}$)
- Incorporates the proven Vaisala HUMICAP[®] sensor, used for over 20 years in oil applications
- Modbus[®] RTU over RS-485
- Traceable calibration certificate: 6 points for humidity, 1 point for temperature
- Compatible with Vaisala Indigo products and Insight PC software

Vaisala HUMICAP[®] Moisture in Oil Probe MMP8 enables fast and reliable measurement of moisture in oil. It uses the proven Vaisala HUMICAP[®] sensor, which was developed for demanding dissolved moisture measurements in transformer and lubrication oils, hydraulic fluids, and other liquids.

Reliable Vaisala HUMICAP[®] technology

MMP8 incorporates the latest-generation Vaisala HUMICAP[®] 180L2 sensor, which is the result of over 20 years of field experience. It was developed for demanding moisture measurement in transformer and lubrication oils and other liquids.

The sensor's excellent chemical tolerance provides accurate and reliable measurement over a wide measurement range. The HUMICAP[®] 180L2 sensor has excellent sensitivity in the dry end of the range, which is typically needed in transformer applications.

Measure the margin to water saturation

MMP8 measures dissolved moisture in oil in terms of the water activity (a_w), relative saturation (%RS), and temperature (T). Water activity or

relative saturation indicate directly whether there is a risk of free water formation. This data is relevant in lubrication oil applications where detecting water ingress and preventing free water formation is crucial. The measurement is independent of oil type and age.

MMP8 can also output ppm, the average mass concentration of water in oil. Vaisala has this conversion readily available for specific oils, including mineral transformer oil. This allows continuous measurement of ppm concentration in power transformer condition monitoring.

For other oils, the oil-specific conversion coefficients can be calculated if the water solubility of the oil is known and the solubility characteristic remains constant.

Easy installation

When installed with an optional ball valve kit, MMP8 is ideal for installation into processes where the probe needs to be installed or removed while the process is running. Probe installation depth is adjustable. Pressure fitting options are ISO 1/2" and NPT 1/2". MMP8 is delivered with a manual pressing handle that allows the probe to be pushed against process pressure.

For more information on Indigo family products and Insight PC software that can be used with the probe, see www.vaisala.com/insight and www.vaisala.com/indigo.

Technical data

Measurement performance

Water activity

Measurement range	0 ... 1 a _w
T ₉₀ response time ¹⁾	10 min
Sensor	HUMICAP® 180L2
Accuracy ²⁾	±0.01 a _w (±1 %RS)

Water concentration in oil

Typical accuracy	10 % of the reading
------------------	---------------------

Temperature

Measurement range	-40 ... +180 °C (-40 ... +356 °F)
Accuracy at +20 °C (+68 °F)	±0.2 °C (0.36 °F)

¹⁾ At +20 °C (+68 °F) in still oil.
²⁾ In range 0 ... 0.5 a_w, including non-linearity, hysteresis, and repeatability. See accuracy graph below.

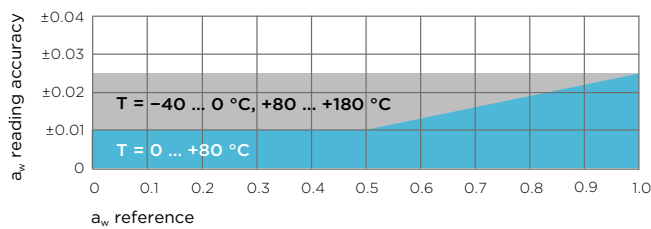

MMP8 A_w measurement accuracy

Operating environment

Operating temperature of probe head	-40 ... +180 °C (-40 ... +356 °F)
Operating temperature of probe body	-40 ... +80 °C (-40 ... +176 °F)
Storage temperature range	-40 ... +80 °C (-40 ... +176 °F)
Operating pressure range	0 ... 40 bar (0 ... 580 psia)
Installation pressure	Up to 10 bar (145 psia)
IP rating of probe body	IP66
Ball valve	
Operating temperature	Up to +120 °C (+248 °F)
Operating pressure	Up to 40 bar (0 ... 580 psia)

Inputs and outputs

Operating voltage	15 ... 30 V DC
Current consumption	10 mA typical
Digital output	RS-485, non-isolated
Protocols	Modbus RTU
Output parameters	Relative saturation (%RS) Temperature (°C) Water activity Water concentration in oil (ppm _v)

Compliance

EU directives and regulations	EMC Directive (2014/30/EU) RoHS Directive (2011/65/EU) amended by 2015/863
EMC compatibility	EN 61326-1, industrial environment
Type approvals	DNV GL certificate no. TAA00002YT
Compliance marks	CE, China RoHS, RCM



Mechanical specifications

Connector	M12 5-pin A-coded male
Weight	510 g (18.0 oz)
Filter options	Stainless steel grid standard filter Stainless steel grid filter for high flow rates (> 1 m/s)
Probe cable length	2 m (6.56 ft)
Adjustable installation depth	35 ... 179 mm (1.37 ... 7.05 in)
Materials	
Probe	AISI 316L
Probe body	AISI 316L
Cable jacket	FEP

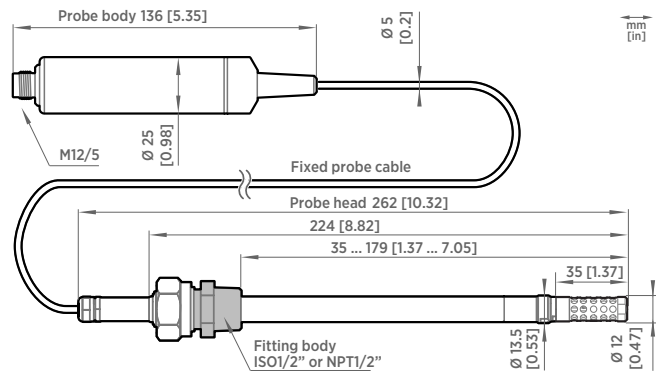

MMP8 dimensions

Accessories

Ball valve kit ISO 1/2" with welding joint	BALLVALVE-1
Ball valve kit ISO 1/2" - ISO 3/4" with thread joint	BALLVALVE-2
Indigo USB adapter ¹⁾	USB2

¹⁾ Vaisala Insight software for Windows available at www.vaisala.com/insight.