

onset®  
**Monitoring Wetlands  
with Data Loggers:  
A Best Practices Guide**



# Monitoring Wetlands with Data Loggers: A Best Practices Guide

<b>INTRODUCTION</b>	<b>2</b>
<b>PROVEN TECHNIQUES FOR INSTALLING DATA LOGGERS IN WETLANDS</b>	<b>3</b>
Data logger overview	3
<b>INSTALLATION AND MOUNTING OPTIONS</b>	<b>4</b>
Installing water level recorders and conductivity sensors underwater	4
Installing weather stations with multiple sensors	5
<b>INSTALLATION TIPS</b>	<b>6</b>
<b>FIELD DEPLOYMENT CHECKLIST</b>	<b>7</b>
Pre-deployment Logger Check and Configuration	7
During deployment	7
Post deployment	7
<b>ADDITIONAL TIPS</b>	<b>8</b>
Use Delayed Start	8
Quality user training	8
Data consistency checks	9
Use protective accessory products	9
<b>IN CONCLUSION</b>	<b>9</b>
<b>ABOUT ONSET</b>	<b>10</b>



## Introduction

New reasons for restoring, conserving, building, and monitoring wetlands are discovered every year. Wetlands act as a natural filter for polluted water and therefore play an essential role in water quality protection. Wetlands also serve as floodwater storage and minimize erosion. Moreover, wetlands create a habitat for many fish and wildlife.

Unfortunately, commercial development, extraction of natural resources, overfishing, and waste have decreased the number of wetlands in the U.S. by almost half since 1950. These acts drain wetlands, exploit underground water tables, or leave sites polluted. As a result of polluted wetlands, not only is wildlife compromised, humans suffer from health problems, → such as respiratory conditions.

On the up side, many organizations make it their mission to restore wetlands back to their original flourishing ecosystems or create new wetlands to replace those that have been eliminated.

To ensure success, it is necessary to monitor wetland environmental conditions such as water level, temperature, and rainfall. This data helps professionals determine progress and evaluate setbacks. Portable data loggers are deployed by numerous experts in the field of wetland monitoring. For example, the U.S. Department of Agriculture uses water level data loggers to monitor wetlands used to absorb pollutants in runoff water from agriculture sites.

In addition, wetland mitigation banks are popping up throughout the U.S. These third-party wetland conservation projects allow companies that negatively impact wetlands to comply with *Section 404 of the Clean Water Act*<sup>1</sup> by funding projects that restore and build new wetlands.

Furthermore, monitoring plays a key role in health assessment of existing wetlands. For example, governments use wetland water level and temperature data to make decisions on zoning and development. Logged data is also used to create water quality standards. For example, the Baylor Experimental Aquatic Research (BEAR) facility develops nutrient criteria for wadeable streams in Texas. BEAR researchers use portable data loggers to acquire data after manipulating environmental parameters within their manmade wetland system.

This white paper shares best practices for configuring and deploying portable data loggers. Tips are also included regarding installation and maintenance.

<sup>1</sup> *Wetlands Compensatory Mitigation published by Environmental Protection Agency.*

## Proven Techniques for Installing Data Loggers in Wetlands

A variety of methods and constructions are used to install portable data loggers in wetland areas. Choosing which method that best meets a project's criteria depends on the project's location, sunlight, water current, and more. The following provides an introduction to data loggers and best practices for a range of installation solutions.

### Data Logger Overview

Data loggers are typically compact electronic recording devices used to gather data for extended periods of time. They record data at prescribed time intervals and then store it. Common data loggers include a microprocessor, high accuracy sensors, and a battery, all enclosed in a rugged housing. These devices are built to withstand wide temperature fluctuations, severe wind, wildlife, and water (including saltwater). Their sizes range from cigar-sized units to pendulums about an inch in diameter.

Some of the most common data loggers used to monitor wetlands are water level, rainfall, water temperature, and air temperature/humidity loggers. The following suggests possible uses for data collection in these applications.

#### Water level

Collected water level data helps researchers determine a variety of factors such as how much water wetlands retain, rising water rate that endanger wildlife habitats, and whether runoff volume efforts are effective.

#### Rainfall

Collected rainfall data indicates how much rain has fallen in a particular area. Researchers often use this data to make comparisons between retained and runoff water. Due to the spatial variability of rain, it is recommended to measure rainfall at multiple sites to come up with an average rainfall for the area.

#### Water temperature

Collected water temperature data is often used to help researchers determine if wetlands are adequately leveling water temperatures before entering waterways.

#### Air temperature/Humidity

Collected air temperature and relative humidity data is typically used to determine the overall health of wetlands and their impact on their respective regions' temperature and humidity. Collected data is typically retrieved by either downloading it to a laptop or a hand-held data shuttle in the field, or via remote communications. Remote communications allow for real time Internet-based access to data. Rather than going out into the field, the user simply logs onto a website to view and download data. This saves travel time and minimizes data gaps due to equipment failure.



Onset's HOBO U20-001-04 Water Level Logger

**When accumulating data from a wetland over several months, one of the biggest challenges is installing the logger in a secure location.**

## Installation and Mounting Options

When accumulating data from a wetland over several months, one of the biggest challenges is installing the logger in a secure location. Here are suggested installations for underwater and in direct sunlight as well as installations with several data loggers. All of which offer great security.

### Installing water level recorders and conductivity sensors underwater

**Cinderblock:** Securing a data logger to a cinderblock is a good option for two reasons. The weight of the block keeps the logger in one location over a long period of time; and if set up correctly, water easily passes through.

- ▶ First, select a PVC pipe large enough to house the logger.
- ▶ Then, drill a hole in the cinderblock large enough to hold the PVC pipe, then slip the pipe through the hole.
- ▶ Next, use zip ties to attach the logger to the pipe. Position the cinderblock on its side to allow water to flow through its openings.

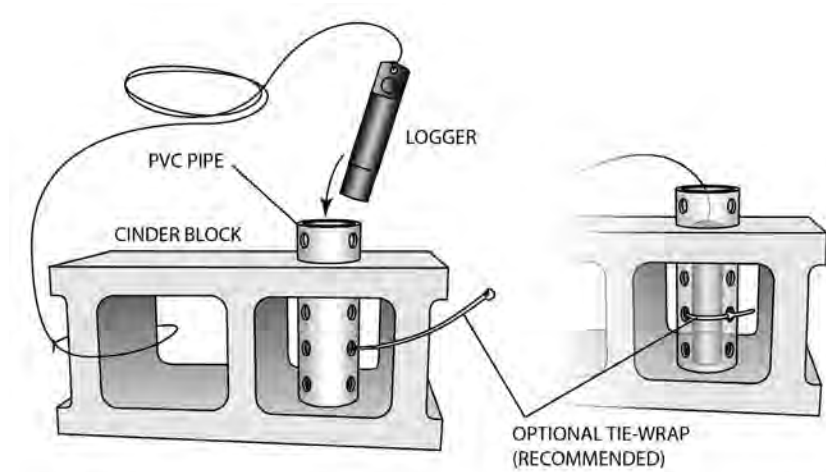

**Arm Hook:** The arm hook construction is best for monitoring waters with minimal flow rates. Since the logger hangs straight, this construction is not feasible for waters with strong currents. To create the arm hook, drill a hole in an 18-inch piece of flat sturdy scrap metal. This metal should not be able to bend. This piece will become the arm. Drill a hole wide enough to slip a ¼-inch ring through. Then weld the arm to a T fence post at the intended logger level position at a 90 degree angle. Part of the post will go into the ground; therefore, include this additional height when calculating the arm position. After the post has been pushed into the soil at the desired location and depth, attach the data logger to a durable mounting hook that fits through the mounting eyelet of the logger. The mounting hook should have captive ends that insure the logger will stay in place. Then slip the hook through the hole on the arm.

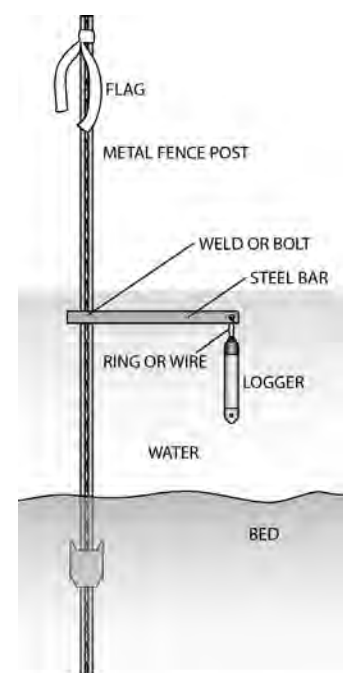

Arm Hook anchoring method

**Stilling Well:** A stilling well provides an area of water with an undisturbed surface. For example, stilling wells are used to protect against waves. First, push a metal T post into the ground at the desired location. Quiet back waters are often a good choice for stilling wells, especially if tracking full tidal cycles. Use hefty zip ties to attach a 4-inch PVC pipe with holes to the T post. If you cannot find a pipe with holes, drill holes as an alternative. Next, attach a wire cable to the data logger and attach the other end of the cable to the top of the pipe. Then, drop the logger into the pipe.

**Simple PVC Pipe:** Use zip ties to attach logger cables to the outside of a 3-foot, 3-inch diameter PVC pipe. Push the PVC pipe into the ground at desired location.

### Installing weather stations with multiple sensors

**Tripod Weather Station:** Build as much of the weather station indoors as possible. This cuts down on losing important small parts. At the site, lay down a tarp and place all tools and components on top. The data logger should be mounted on the mast so that the cables come out the bottom of the logger. This enables cables to hang down, which prevents water drops on the cables from entering. Anchor legs with rebar stakes through the feet of the tripod. Then, add guy wires. Finally, flag guy wires so people and animals do not trip or run into them.

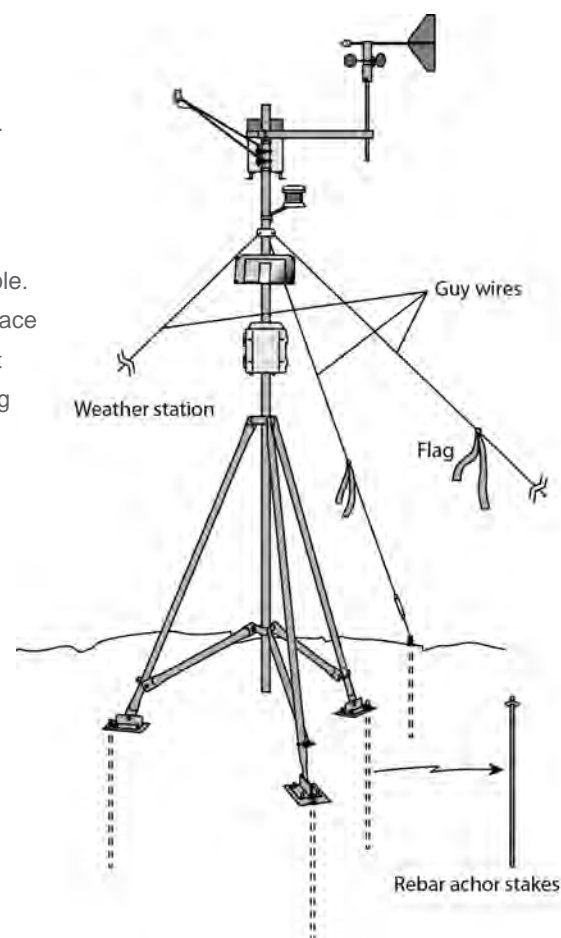

**Rodents and other animals can chew through data logger cables. To avoid this, run data logger cables through conduit.**

## Installation Tips

In addition to making sure data loggers are securely installed, measures need to be taken to keep the loggers out of direct sunlight and protected from damage caused by weather, chemical conditions, and wildlife.

**Avoiding Elevating Temperatures:** When acquiring temperature data in wetlands, direct sunlight can affect readings. To avoid inaccuracy, use only white PVC pipe for both stilling wells and simple PVC pipe installations. White reflects light and therefore reduces solar radiation. When using the simple PVC pipe installation, push the pipe into the wetland area so the data logger sensors face north (in the northern hemisphere.) This helps avoid direct light hitting the sensors. Note: If using the stilling well method, inspect the pipe regularly for algae buildup. If enough algae grows on the pipe, temperatures within the pipe can rise. To remedy this, clean the pipe regularly. Another way to avoid elevated temperatures is placing data loggers in a cinderblock, as discussed above. This method keeps data loggers shaded while submerged in water.

**Avoiding Corrosion of Metal Parts:** Metal hooks, chains, and other metal pieces can easily corrode over time in a wetland. This corrosion is caused by fluctuation between aerobic and anaerobic conditions.

To avoid corrosion, spray metal posts with primer. Spray metal hooks and chains with vinyl spray paint such as Spray-on Vinyl. These precautions help keep data loggers properly installed over long periods.

**Protecting Equipment from Animals:** Rodents and other animals can chew through data logger cables. To avoid this, run data logger cables through conduit. In addition, bird excrement can clog rain gages. To prevent this, use bird deterrent spikes, such as those from Bird-X around the outside of the rain gauge collector funnel, or clean out rain gages periodically.

## Field Deployment Checklist

The following are examples of checklist items to work through periodically before and during data logger deployment.

### Pre-deployment

- Before launching the loggers, be sure to set computer used to launch the loggers to the proper time zone.
- Check battery status before launching loggers.
- Confirm loggers are set to proper logging interval. (If a logger is set to “every second” by mistake, data storage will fill up quickly and anticipated data will never be recorded.)
- Verify proper operation by checking all loggers five minutes after they have been launched to confirm loggers have been setup correctly.



### During Deployment

- Log the specific location of each logger in your field notebook so the loggers can be easily found. This can be accomplished by noting their GPS locations and taking photos of their locations.

### Post Deployment

- Check location to confirm logger has not moved.
- Periodically offload data to provide backup in the event the loggers are lost or damaged later.
- Check battery power.
- Look for algae growth.
- Look for corrosion.
- Check protective casing for breakage.
- Check zip ties for damage.



## Additional Tips

Here are additional tips to help attain accurate results:

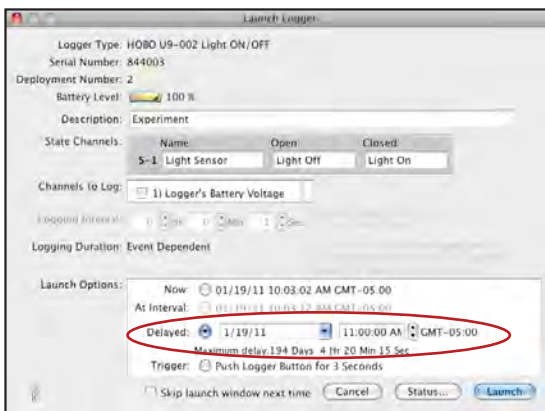

### Use Delayed Start

Most portable data loggers provide a delayed start function. This function allows users to set logging options in the comfort of an office, lab, or other location where double checking key settings is easier. Using a delayed start is highly

recommended, and helps when field weather conditions could damage computer equipment. With delayed start, users do not need to take computers on site to deploy loggers.

### Quality User Training

Fully train new users assigned to setup and deploy data loggers offsite before launching loggers. For example, new users can launch water level and temperature loggers in a fish tank. They can also practice downloading data in the lab.

### Data Consistency Checks

When using multiple loggers of the same type, before installing, launch all loggers to start logging immediately and locate them together in one area (such as a fish tank or sitting on a bench). Let the loggers run for 48 hours to check their data for consistency. If inconsistencies are found, replace the deviant loggers.

Likewise, if multiple loggers of the same type have been deployed, do not turn loggers off immediately after they are retrieved from a deployment. Instead, set all loggers in one place and let them run for an additional 48 hours. Then offload the logger data and check for inconsistent data. If data is inconsistent, use the acquired data to calculate a correction factor for the deviant loggers.

## Use Protective Accessory Products

In addition to the rugged built-in housing, data logger suppliers often offer supplementary accessories to ensure devices are secure in every climate and weather condition. Here are three examples:

- When using loggers with optic communications, such as the HOBO Water Temp Pro v2 from Onset, it is recommended to cover the communication window with a cap or tape to prevent residue buildup that could affect communications.
- For additional protection in harsh conditions, thermoplastic elastometer boots are available for many loggers, such as Onset TidbiT® data loggers to provide cushioning. This product is offered in white to minimize solar radiation absorption, or black for additional camouflage.
- Protective housings are available to protect the loggers while still allowing easy access to the loggers for data offload.



Onset's HOBO® Water Temp Pro v2 Logger

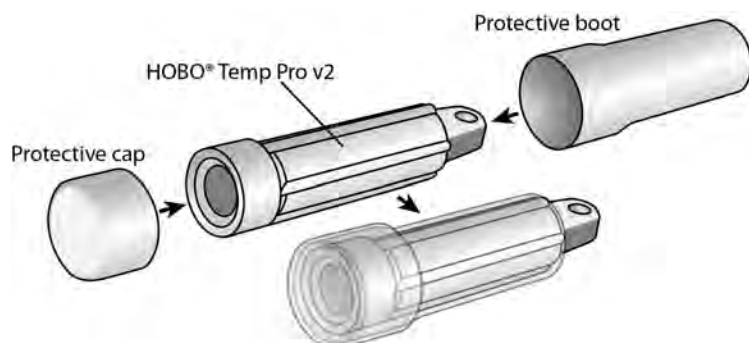

## Conclusion

Wetland monitoring is becoming more widely performed and developing into a necessity for several industries. Various organizations use wetland monitoring to assess wetland health, create environmental standards, and study climate change. Restoration and mitigation are also growing fields of research and business. The best practices shared in this white paper support are conducted by several experts in their respective fields. Collaboration of experienced professionals fuels innovation and in this case, a better, healthier environment.

## About Onset

Onset is the world's leading supplier of data loggers. Our HOBO data logger products are used around the world in a broad range of monitoring applications, from verifying the performance of green buildings and renewable energy systems to agricultural and coastal research.



Based on Cape Cod, Massachusetts, Onset has sold more than 1.5 million data loggers since the company's founding in 1981.



*Onset headquarters, Cape Cod, MA*

## Contact Us

Our goal is to make your data logging project a success. Our skilled application specialists are standing by to discuss your needs and recommend the right solution for your project.

-  Speak with an application specialist by calling **1-800-564-4377**
-  Email your inquiry to [sales@onsetcomp.com](mailto:sales@onsetcomp.com)
-  Go to **onsetcomp.com** to browse our white papers, application stories, videos, and webinars

Onset  
470 MacArthur Boulevard  
Bourne, MA 02532



