



RFL100 Wireless Data Logger for Continuous Monitoring Systems



Features

- Industry-leading temperature and relative humidity measurement precision
- Detachable high-accuracy RH and temperature probes
- 30-day First In First Out (FIFO) memory buffer
- Optional magnetic mounting bracket available
- Typical battery life of 18 months
- Uses standard alkaline batteries
- Traceable to SI units through national metrology institutes ¹⁾
- Cost-effective alternative to chart recorders

¹⁾ Measurement results are traceable to the International System of Units (SI) through national metrology institutes (NIST USA, MIKES Finland, or an equivalent) or accredited calibration laboratories.

RFL100 Data Logger uses Vaisala's proprietary VaiNet wireless technology. It can be used to monitor temperature and humidity in a wide range of environments: warehouses, production areas, cleanrooms, laboratories, fridges, cold storage areas, and freezers down to -196 °C (-320.8 °F).

VaiNet Wireless

RFL100 connects wirelessly to Vaisala viewLinc Monitoring System, which provides real-time trends, alarms, and historical reporting. VaiNet wireless technology is based on the LoRa[®] modulation technique to provide a robust wireless signal that is extremely reliable over long distances and in complex, obstructed conditions. This wireless technology allows the data logger's signal to travel over 100 m (328 ft) indoors without the aid of signal amplifiers or repeaters. Wireless communications are encrypted to ensure data integrity and security.

Measurements are updated and stored every 60 seconds, and sent from the data logger every four minutes. In case of temporary network disruptions, the data logger can record up to 30 days of

measurements that are automatically transmitted to the viewLinc Enterprise Server software when communications are restored. Recorded data can also be downloaded directly from RFL100 through the USB port.

Versatility and Convenience

RFL100 requires no startup configuration, and the included mounting bracket supports several installation methods. Detailed custom display shows the latest measurement results, alarm and battery status, and signal strength of the current access point connection. The housing is classified IP54 to protect the device from dust and cleaning.

RFL100 is powered by two standard AA size 1.5 V batteries (LR6 alkaline or FR6 lithium) for 18 months of operation at approximately 20 °C (68 °F). There is no need for costly battery replacements between recommended calibrations.

Detachable Probe

RFL100 supports several probe types for humidity and temperature measurement. The probes use Vaisala HUMICAP[®] humidity sensors and platinum temperature sensors (Pt100 and Pt1000 type) for superior stability. Probes can be integrated with the RFL100 housing or connected using a cable.

The probe is detachable, and easy to switch out for calibration. viewLinc Enterprise Server detects the changed probe information automatically and maintains accurate and complete historical records.

Probe Options

HMP115 Probe



Probe for general purpose humidity and temperature measurement. Ideal choice for ambient measurement. Designed to be integrated with RFL100 housing for minimum footprint, but can be connected using a cable as well.

Plastic grid filter provides the fastest response time. For added sensor protection, select the membrane filter or the PTFE filter.

HMP110 Probe



Robust stainless steel probe for humidity and temperature measurement in demanding conditions. Suitable for measurement inside chambers, fridges, and freezers. Cable probe option only. Probe diameter 12 mm (0.47 in).

Plastic grid filter provides the fastest response time. For added sensor protection, select the membrane filter, the PTFE filter, or the stainless steel sintered filter.

TMP115 Probe



Wide-range temperature-only probe for measurement in extreme conditions. Can be integrated with the RFL100 housing or connected using a cable.

Available as 50 cm (1 ft 7.7 in) and 3 m (9.8 ft) long versions. Length includes probe body and sensor tip. Sensor tip withstands immersion in glycol and liquid nitrogen. Sensor tip diameter 4.8 mm (0.19 in).

Probe Model	Measurement	Measurement Temperature Range	IP Rating	Typical Mounting Accessories
HMP115	RH + T	-40 ... +60 °C (-40 ... +140 °F)	IP54	No accessories needed when integrated to RFL100
HMP115T	T	-40 ... +60 °C (-40 ... +140 °F)	IP54	
HMP110	RH + T	-40 ... +80 °C (-40 ... +176 °F)	IP65	<ul style="list-style-type: none"> • Duct installation kit • Mounting clamps • Mounting nuts
HMP110T	T	-40 ... +80 °C (-40 ... +176 °F)	IP65	
TMP115	T	-196 ... +90 °C (-320.8 ... +194 °F)	IP67 (sensor tip) IP65 (probe body)	<ul style="list-style-type: none"> • Thermal dampener block • Flat cable for insertion to chambers and freezers via door seal

Technical Data

Wireless

Networking standards	Vaisala VaiNet
Modulation	LoRa™ chirp spread spectrum modulation
Output power	14 dBm (25 mW)
Antenna	Internal
Typical range (indoors)	At least 100 m (328 ft)
Range with line-of-sight	Over 500 m (1640 ft)
Frequency bands	868 MHz (Europe) 915 MHz (North America, Australia, and New Zealand)
Safety	
Electrical safety	EN/UL/IEC 61010-1
RF exposure	KDB 447498 (United States) RSS-102 Issue 5 (Canada)
EMC and Radio Standards	
EMC compliance	EN/IEC 61326-1, industrial environment
868 MHz model	ETSI EN 300 220-2 EN 301 489-1 EN 301 489-3
915 MHz model	FCC title 47 part 15.247 (FCC ID: 2A039-RFL100A) ICE RSS-247 (IC: 23830-RFL100A) AS/NZS 4268

Memory

Sample capacity	30 days (43200 samples per channel)
Memory type	Non-volatile EEPROM
Memory mode	Ring buffer (FIFO)
Sampling rate	One sample / channel / minute (nonchangeable)

Operating Environment

Storage temperature	-40 ... +60 °C (-40 ... +140 °F)
Operating humidity	0 ... 100 %RH, non-condensing
Operating Temperature ¹⁾	
with alkaline batteries	+2 ... +60 °C (+35.6 ... +140 °F)
with lithium batteries	-20 ... +60 °C (-4 ... +140 °F)

¹⁾ For both alkaline and lithium, battery temperature operating specifications apply.

General

Compatible probes	HMP115, HMP115T HMP110, HMP110T (cabled only) TMP115
Compatible viewLinc versions	5.0 and above
Batteries	2 × AA sized, 1.5 V (LR6 or FR6)
Clock battery	CR 1/3N (3 V lithium button cell)
Operation time at 20 °C (without external power supply)	18 months
Internal clock accuracy	±30 s/month Synchronizes with Network Time Protocol (NTP) server

Mechanical Specifications

Housing color	White
Mounting methods	Screws, tie-wrap, hook, or magnetic mounting bracket (optional accessory)
Probe interface	4-pin female M8 connector
Service port	USB 2.0 with Micro-USB connector
IP rating	IP54
Dimensions (H × W × D) with HMP115 Probe	
Without mounting bracket	158 × 62 × 31 mm (6.22 × 2.4 × 1.22 in)
With mounting bracket	186 × 68 × 36.5 mm (7.32 × 2.68 × 1.44 in)
Weight	
With batteries (2 pcs alkaline), HMP115 probe, and magnetic mounting bracket	254 g (8.96 oz)
Materials	
Housing	PC/ABS blend
Display window	PMMA (acrylic)
Sealings	TPE

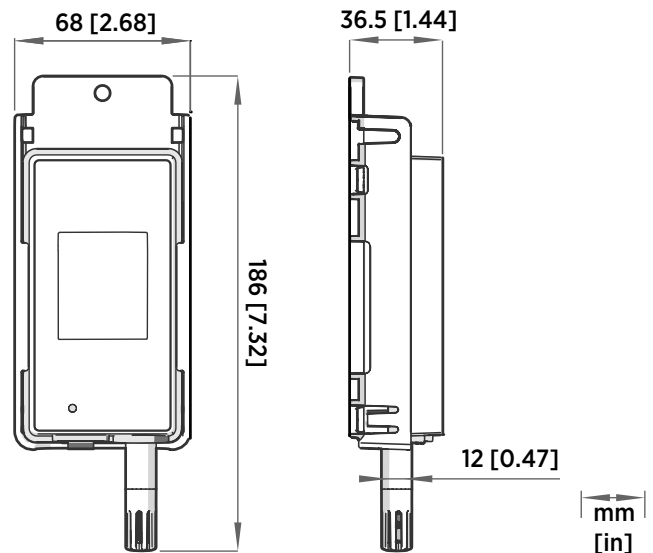

RFL100 Dimensions with HMP115 Probe

HMP110/T Probe Measurement Performance

Relative Humidity

Measurement range 0 ... 100 %RH

Accuracy in Temperature Range 0 ... +40 °C (+32 ... +104 °F) ¹⁾

0 ... 90 %RH ±1.5 %RH
90 ... 100 %RH ±2.5 %RH

Accuracy in Temperature Range -40 ... 0 °C, +40 ... +80 °C (-40 ... +32 °F, +104 ... +176 °F) ¹⁾

0 ... 90 %RH ±3.0 %RH
90 ... 100 %RH ±4.0 %RH

Factory Calibration Uncertainty at +20 °C (68 °F) ²⁾

0 ... 90 %RH ±1.1 %RH
90 ... 100 %RH ±1.8 %RH

Humidity sensor Vaisala HUMICAP® 180R

Stability ±2 %RH over 2 years

Temperature

Measurement range -40 ... +80 °C (-40 °F ... +176 °F)

Accuracy over Temperature Range

at 0 ... +40 °C (+32 °F ... +104 °F) ± 0.2 °C (0.36 °F)
at -40 ... 0 °C, +40 ... +80 °C (-40 ... +32 °F, +104 ... +176 °F) ± 0.4 °C (0.72 °F)

Factory calibration uncertainty ²⁾ ± 0.2 °C (0.36 °F)

Temperature sensor Pt1000 RTD Class F0.1 IEC 60751

¹⁾ Includes non-linearity, hysteresis, and repeatability.

²⁾ Small variations possible; see also calibration certificate.

HMP115/T Probe Measurement Performance

Relative Humidity

Measurement range 0 ... 100 %RH

Accuracy in Temperature Range 0 ... +40 °C (+32 ... +104 °F) ¹⁾

0 ... 90 %RH ±1.5 %RH
90 ... 100 %RH ±2.5 %RH

Accuracy in Temperature Range -40 ... 0 °C, +40 ... +60 °C (-40 ... +32 °F, +104 ... +140 °F) ¹⁾

0 ... 90 %RH ±3.0 %RH
90 ... 100 %RH ±4.0 %RH

Factory Calibration Uncertainty at +20 °C (68 °F) ²⁾

0 ... 40 %RH ±0.6 %RH
40 ... 75 %RH ±1.0 %RH

Humidity sensor Vaisala HUMICAP® 180R

Stability ±2 %RH over 2 years

Temperature

Measurement range -40 ... +60 °C (-40 °F ... +140 °F)

Accuracy over Temperature Range

at 0 ... +40 °C (+32 ... +104 °F) ± 0.2 °C (0.36 °F)
at -40 ... 0 °C, +40 ... +60 °C (-40 ... +32 °F, +104 ... +140 °F) ± 0.4 °C (0.72 °F)

Factory calibration uncertainty ²⁾ ± 0.1 °C (0.18 °F)

Temperature sensor Pt1000 RTD Class F0.1 IEC 60751

¹⁾ Includes non-linearity, hysteresis, and repeatability.

²⁾ Small variations possible; see also calibration certificate.



TMP115 Probe Measurement Performance

Temperature

Measurement range -196 ... +90 °C (-320.8 ... +194 °F)

Accuracy over Temperature Range ¹⁾

at -196 ... -90 °C (-320.8 ... -130 °F) ± 2.5 °C (4.5 °F)

at -90 ... -30 °C (-130 ... -22 °F) ± 0.75 °C (1.35 °F)

at -30 ... 0 °C (-22 ... +32 °F) ± 0.5 °C (0.9 °F)

at 0 ... +50 °C (+32 ... +122 °F) ± 0.25 °C (0.45 °F)

at +50 ... +90 °C (+122 ... +194 °F) ± 0.75 °C (1.35 °F)

Factory calibration uncertainty ²⁾ ± 0.08 °C (0.128 °F)

Temperature sensor Pt100 RTD Class A IEC 751

¹⁾ Includes non-linearity, hysteresis, and repeatability.

²⁾ Small variations possible; see also calibration certificate.