

Mounting Instructions for MSR Shock and Vibration Data Loggers

MSR 165, MSR 175, MSR 175plus

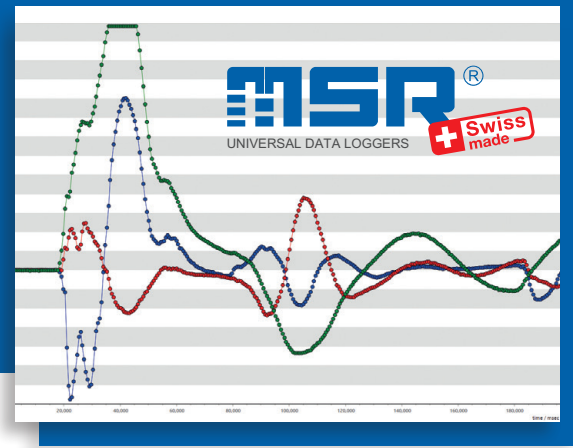

Precise recording of the actual dynamic load

The correct mounting of the data loggers is crucial for the correct measurement of the dynamic loads (shock/vibration). Before starting data recording, check that the data loggers have been mounted correctly. **The data loggers should be force-fitted as close as possible to or on the object to be monitored.** Fastening to the packaging or the means of transport will lead to deviating results. Screw the data loggers to the object in the holes provided. Alternatively, the data loggers can also be fastened with high-strength industrial adhesive tape or cable ties. Magnetic fastening should be avoided, it only acts in the direction of the magnetic field lines – is not force-locking.

Orientation

Align the axes of the data loggers with the main directions of movement. The data loggers can be mounted in any position. Make a note of the position and direction of the axes for later evaluation.

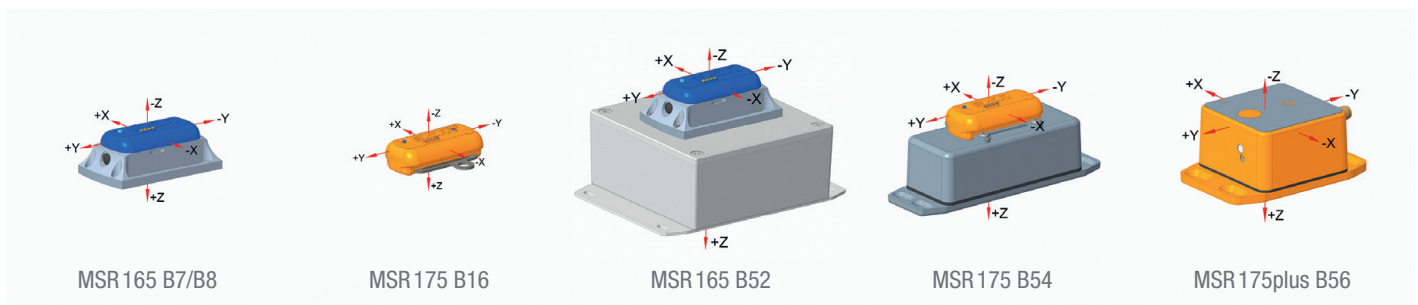

Determination of the slope

The ± 15 sensor additionally measures gravity (direction to the center of the earth $\approx 1g$). Due to the static position, the inclination can also be determined. Example $0 \dots \pm 180^\circ$: $ACC_x = -0.518g$, $ACC_y = 0.425g$, $ACC_z = 0.741g$:

MSR 145, MSR 165

Port:

ACCx	= 0.514 g
ACCy	= 0.255 g
ACCz	= 0.817 g

MSR 175

Environmental data

Measure rate: Every 10 minutes







Temperature: 24.2 °C Battery: 4.1 V

Position X: 0.640 g
Position Y: -0.544 g
Position Z: 0.600 g

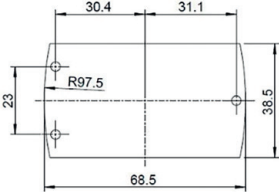
MSR PC-Software: In the setup with «Read» on the MSR 145 / MSR 165 or «Click here to view values» on the MSR 175 and MSR 175plus, the current values ACCx, ACCy, ACCz can be read.

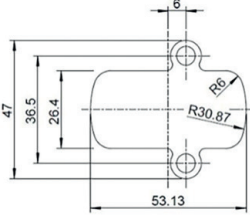
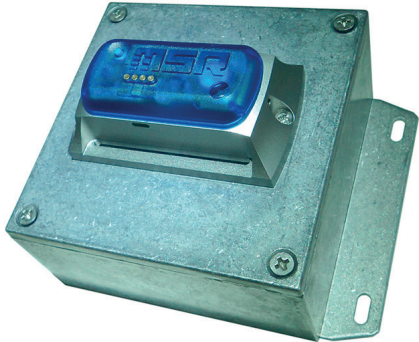
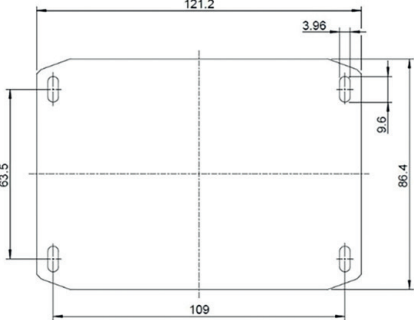
$$\begin{aligned} \text{Rotation around the } x - \text{axis} &= \arctan \frac{ACC_y}{ACC_z} = \arctan \frac{0.425}{0.741} = 0.52074 \text{ rad} \cdot \frac{180}{\pi} = 29.84^\circ \\ \text{Rotation around the } y - \text{axis} &= \arctan \frac{ACC_z}{ACC_x} = \arctan \frac{0.741}{-0.518} = -0.96070 \text{ rad} \cdot \frac{180}{\pi} = -55.04^\circ \\ \text{Rotation around the } z - \text{axis} &= \arctan \frac{ACC_z}{ACC_y} = \arctan \frac{0.741}{0.425} = 1.05005 \text{ rad} \cdot \frac{180}{\pi} = 60.16^\circ \end{aligned}$$

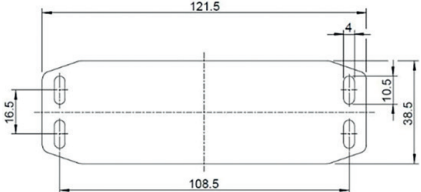
Mounting recommendation for data loggers MSR 165, MSR 175, MSR 175plus

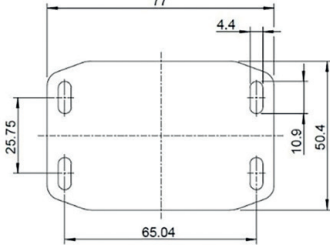
Housing types	Outlines, Hole patterns	Screw connections
<p>MSR 165 B7/B8</p> 		<p>Thread assembly: e.g. DIN 965A / ISO 7046 A2 M3x8 Tightening torque: 0.45-0.55 Nm</p> <p>Mounting in wood and sheet metal: e.g. DIN 7983C / ISO 7051 A2 2.9x19 Tightening torque: 0.4-0.5 Nm</p>
<p>MSR 175 B16</p> 		<p>Thread assembly: e.g. DIN 7085A / ISO 7045 A2 M6x12 Tightening torque: 4.5-5.0 Nm</p> <p>Mounting in wood and sheet metal: e.g. DIN 7981C / ISO 7049 A2 5.5x19 Tightening torque: 4.0-4.5 Nm</p>
<p>MSR 165 B52</p> 		<p>Thread assembly: e.g. DIN 7085A / ISO 7045 A2 M4x10 Tightening torque: 1.2-1.4 Nm</p> <p>Mounting in wood and sheet metal: e.g. DIN 7981C / ISO 7049 A2 5.5x19 Tightening torque: 1.0-1.2 Nm</p>
<p>MSR 175 B54</p> 		<p>Thread assembly: e.g. DIN 7085A / ISO 7045 A2 M4x10 Tightening torque: 1.2-1.4 Nm</p> <p>Mounting in wood and sheet metal: e.g. DIN 7981C / ISO 7049 A2 5.5x19 Tightening torque: 1.0-1.2 Nm</p>
<p>MSR 175plus B56 ¹⁾</p> 		<p>Thread assembly: e.g. DIN 965A / ISO 7046 A2 M4x12 Tightening torque: 1.2-1.4 Nm</p> <p>Mounting in wood and sheet metal: e.g. DIN 7983C / ISO 7051 A2 3.5x19 Tightening torque: 1.0-1.2 Nm</p>

¹⁾ The GPS antenna of data logger MSR 175plus, housing type B56 should be attached to the outside of the packaging. The back of the antenna is magnetic. On a non-magnetic body it can be positioned and secured with a wrapping foil.