

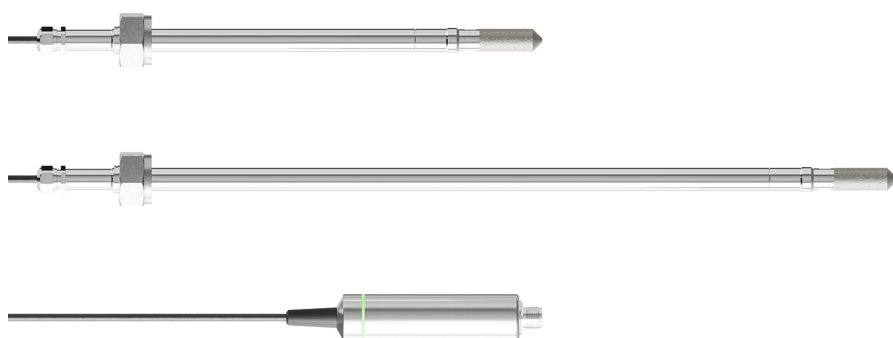

HMP8 Relative Humidity and Temperature Probe

For pressurized and vacuum processes



Features

- RH accuracy up to ± 0.8 %RH
- Temperature accuracy up to ± 0.1 °C (± 0.18 °F)
- Operating pressure 0–40 bar
- Temperature measurement range $-70 \dots +180$ °C ($-94 \dots +356$ °F)
- Sensor purge improves long-term stability and chemical resistance
- Two lengths available for the probe head: 268 mm and 454 mm
- Probe installation depth can be freely adjusted and probe can be hot-swapped from pressurized pipelines with an optional ball valve kit
- Modbus® RTU over RS-485
- Compatible with Vaisala Indigo products and Insight PC software
- Traceable calibration certificate: 6 points for humidity, 1 point for temperature

Vaisala HUMICAP® Humidity and Temperature Probe HMP8 is designed for pressurized applications in compressed air systems, refrigerant dryers, and other pressurized industrial applications, where easy insertion and removal of the probe and adjustable installation depth into the pipeline are needed.

Proven Vaisala HUMICAP® performance

Vaisala is the original innovator of the thin-film capacitive humidity measurement technology, which has now become the industry standard in humidity measurement.

HUMICAP® technology results from Vaisala's 40-year experience in industrial humidity measurement, providing the best stability, fast response time, and low hysteresis in a wide range of applications.

Sensor purge minimizes effects of contaminants

In environments with high concentrations of chemicals and cleaning agents, the sensor purge option helps to maintain measurement accuracy between calibration intervals.

Sensor purge involves heating the sensor to remove harmful chemicals. The function can be initiated manually or programmed to occur at set intervals.

Flexible connectivity

The probe can be used as a standalone digital Modbus RTU transmitter over an RS-485 serial bus, and it can also be connected to Indigo transmitters and the Indigo80 handheld indicator. For easy-to-use access to field calibration, device analytics, and configuration functionality, the probe can be connected to Vaisala Insight software for Windows®. For more information, see www.vaisala.com/insight.

Vaisala Indigo product family

Indigo transmitters extend the capabilities of Indigo-compatible measurement probes. The transmitters can display measurements on the spot as well as transmit them to automation systems through analog signals, digital outputs, and relays. Cable length between probe and transmitter can be extended to up to 30 meters.

The Indigo80 handheld indicator is ideal for spot-checking and process monitoring, as well as for configuring, troubleshooting, calibrating, and adjusting the probe. For more information, see www.vaisala.com/indigo.

Technical data

Measurement performance

Relative humidity

Measurement range 0–100 %RH, at max. +95 °C (203 °F) T_d

Accuracy at +23 °C (+73.4 °F)¹⁾ ±0.8 %RH (0–90 %RH)

Factory calibration uncertainty²⁾ ±0.5 %RH (0–40 %RH)
±0.8 %RH (40–95 %RH)

T₆₃ response time 15 s

Sensor options HUMICAP® R2
HUMICAP® R2C³⁾

Temperature

Measurement range –70 ... +180 °C (–94 ... +356 °F)

Accuracy at +23 °C (+73.4 °F)¹⁾ ±0.1 °C (±0.18 °F)

Factory calibration uncertainty²⁾ ±0.1 °C (±0.18 °F) at +23 °C (+73.4 °F)

Sensor Pt100 RTD Class F0.1 IEC 60751

- 1) Defined against calibration reference. Including non-linearity, hysteresis, and repeatability.
2) Defined as ±2 standard deviation limits. Small variations possible; see calibration certificate.
3) Sensor purge feature available with this sensor.

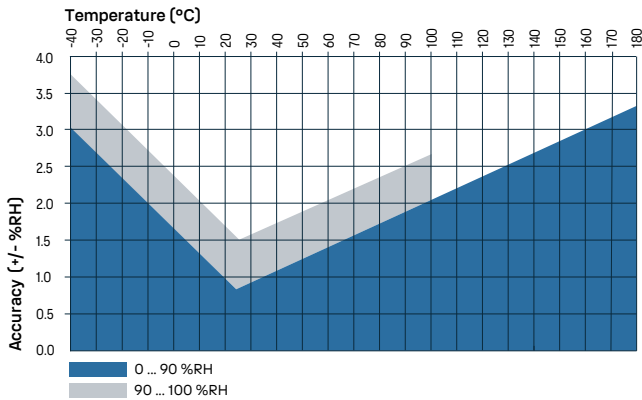

HMP8 humidity measurement accuracy as a function of temperature

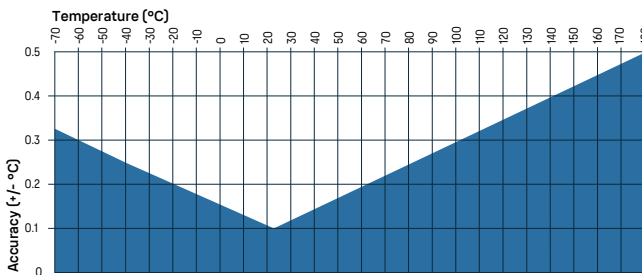

HMP8 temperature measurement accuracy over full range

Operating environment

Operating temperature of probe body –40 ... +80 °C (–40 ... +176 °F)

Operating temperature of probe head –70 ... +180 °C (–94 ... +356 °F)

Operating humidity of probe head Max. +100 °C (212 °F) T_d

Storage temperature –40 ... +80 °C (–40 ... +176 °F)

Operational pressure < 40 bar

Operating environment Suitable for outdoor use

Measurement environment For air, nitrogen, hydrogen, argon, helium, oxygen, and vacuum¹⁾

IP rating of probe body IP66

Ball valve

Operating temperature Up to +100 °C (+212 °F)

Operating pressure Up to 40 bar (580 psi), absolute

¹⁾ Consult Vaisala if other chemicals are present. Consider safety regulations with flammable gases.

Inputs and outputs

Operating voltage 15–30 V DC

Current consumption 10 mA typical, 500 mA max.

Digital output RS-485, non-isolated

Protocols Modbus RTU

Output parameters

Absolute humidity (g/m³) Relative humidity (%RH)

Absolute humidity at NTP (g/m³) Relative humidity (dew/frost) (%RH)

Dew point temperature (°C) Temperature (°C)

Dew/frost point temperature (°C) Water concentration (ppm_v)

Dew/frost point temperature at 1 atm (°C) Water concentration (wet basis) (vol-%)

Dew point temperature at 1 atm (°C) Water mass fraction (ppm_w)

Dew/frost point depression (°C) Water vapor pressure (hPa)

Enthalpy (kJ/kg) Water vapor saturation pressure (hPa)

Mixing ratio (g/kg) Wet-bulb temperature (°C)

Compliance

EU directives and regulations EMC Directive (2014/30/EU)
RoHS Directive (2011/65/EU) as amended by 2015/863

Electromagnetic compatibility (EMC) EN 61326-1, industrial environment

Type approvals DNV GL certificate no. TAA00002YT¹⁾

Compliance marks CE, China RoHS, RCM

¹⁾ DNV GL certificate applies to the 268-mm-long HMP8 model only, not to the 454-mm-long model.



Mechanical specifications

Connector	M12 5-pin A-coded male
Probe fitting	ISO1/2" and NPT1/2" fittings included
Weight (with a 2-m cable)	268-mm-long HMP8: 512 g (18.1 oz) 454-mm-long HMP8: 612 g (21.6 oz)
Probe cable length	2 m (6.56 ft) or 10 m (32.80 ft)
Adjustable installation depth	268-mm-long HMP8: 41-199 mm (1.61-7.83 in) 454-mm-long HMP8: 41-385 mm (1.61-15.16 in)

Materials

Probe	AISI 316L
Probe body	AISI 316L
Cable jacket	FEP

Accessories

Ball valve kit ISO 1/2" with welding joint	BALLVALVE-1
Indigo USB adapter ¹⁾	USB2
Calibration adapter for HMK15	211302SP
Weatherproof carrying case for Indigo80 and a series 8 probe ²⁾	ASM215318

¹⁾ Vaisala Insight software for Windows available at www.vaisala.com/insight.

²⁾ For example, MMP8, HMP8, or DMP8 with a max. 2-m (6.6-ft) probe connection cable.

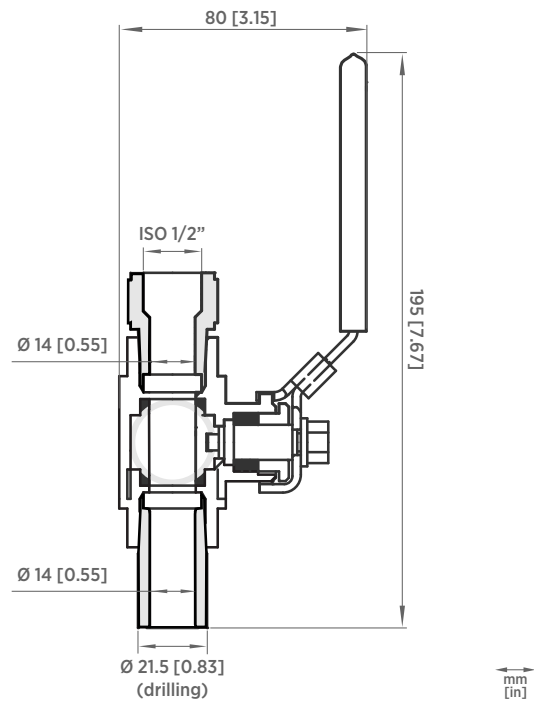

Ball valve kit dimensions

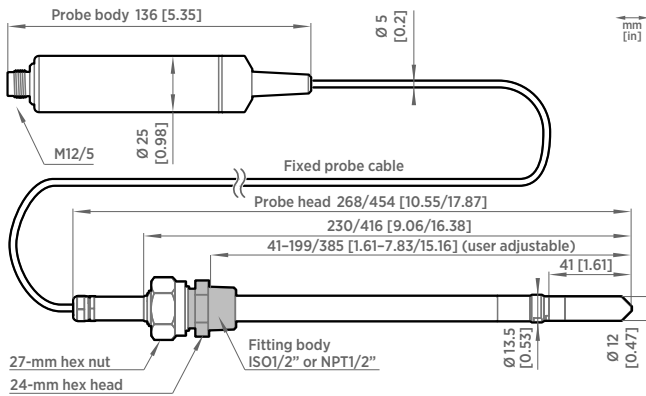

HMP8 probe dimensions